

Belt Conveyor

Typ - BT



Leif Åhl Verkstad AB
Your complete supplier

Belt Conveyor Typ BT Measurement

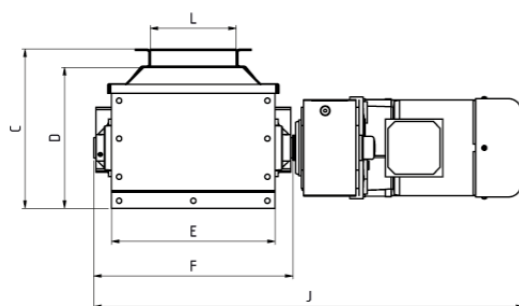
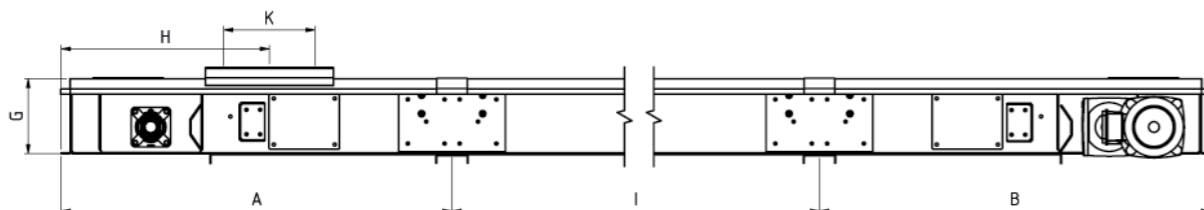

Type:	A	B	C	D	E	F	G	H	I	J	K	L
250-/165	1282	1282	313	277	324	394	245	683	400-2500	Depending of gear	300	170
350-/165	1282	1282	348	300	424	500	268	735	400-2500	Depending of gear	400	210
500-/165	1282	1282	330	370	574	635	340	709	400-2500	Depending of gear	500	280

Machine type:

The choice of machine depends on the capacity and load.

The table below shows the general recommendations of the machine relative to the conveyor length.

Capacity:

Type:	Theoretical volume per/m
250-I/165	8,5 liters
350-I/165	17 liters
500-I/165	28 liters

Capacity at different belt speeds:

Type:	250-I/165	350-I/165	500-I/165
0,8 m/s	24 m ³ /h	50 m ³ /h	80 m ³ /h
1,0 m/s	30 m ³ /h	60 m ³ /h	100 m ³ /h
1,2 m/s	36 m ³ /h	75 m ³ /h	120 m ³ /h
1,4 m/s	42 m ³ /h	85 m ³ /h	140 m ³ /h
1,6 m/s	49 m ³ /h	98 m ³ /h	160 m ³ /h

Ahlright Belt Conveyor Type - BT is a serie of enclosed belt conveyors for 100% dust-proof transport of grains and powder products such as grains, pellets, chips, chemicals, plastic granules and similar.

The belt is guided and shaped by a sheet metal design / sliding tray which is to achieve a special edge sealing.

This means 100% clean and dust-free transport of the material.

The inner and outer tray and the lid forms a closed and bearing construction.

As standard, the carrier chassis is made entirely of galvanized sheet steel with a sliding tray in stainless steel.

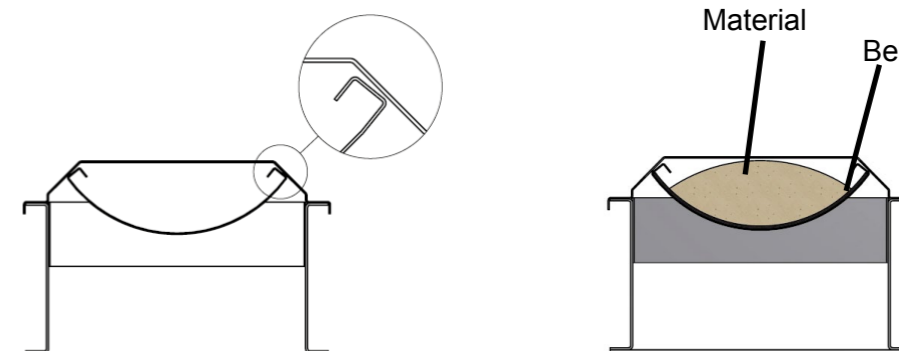

Advantages and characteristics of belt conveyor Ahlright:

- Clean - unique sealing system
- Closed - 100% dustproof
- Ergonomic - silent
- Gentle - no product wear
- Module built - great flexibility
- High capacity - despite the small footprint
- Low weight - sliding tray instead of rollers
- Reversibel - standard

The picture shows the principle for the transport of material on the belt, in this case wood pellets.



LEIF ÅHL
Verkstad AB

*Leif Åhl Verkstad AB
Saleby, Erik-Larsgården 11
SE-531 93 Lidköping*

*Phone: 0510-53 00 28
Mail: info@ahlverkstad.com*

www.ahlverkstad.com